



CONDOR C1919 GPS RECEIVER MODULE

TECHNICAL HIGHLIGHTS

Receiver: GPS L1 frequency (1575.42 MHz), C/A code, 22-channel continuous tracking

NMEA output and input: serial port

On-board low noise amplifier

Use with passive or active antennas; with active antennas, the maximum gain at the RF input is 25 dB.

Built-in antenna circuit protection in C1919C variant

SBAS (WAAS, EGNOS, MSAS) capable

aGPS capable

Update rate up to 5 Hz

PPS timing output

28 surface mount castellations

C1919A variant is also available mounted on a carrier board or in a starter kit

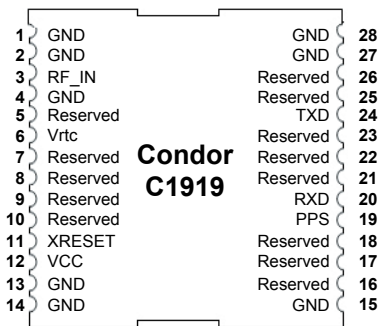

Pin Out Diagram

GENERAL OVERVIEW

Trimble's Condor C1919 GPS receiver module is a smart alternative to a GPS chipset for many consumer and commercial positioning applications. Use the C1919 to bring innovative products to market faster.

The Condor C1919 receiver features powerful positioning performance in a 19.0 mm x 19.0 mm x 2.54 mm package.

The module's 28 reflow-solderable surface-mount edge castellations provide an interface for your design without the need for costly I/O and RF connectors.

The Condor C1919 provides an L1 Frequency GPS receiver, with NMEA protocol from a serial port, and also a PPS timing output.

The C1919 has an onboard low noise amplifier (LNA) that is compatible with both active and passive antenna implementations. It includes an onboard RTC and TCXO.

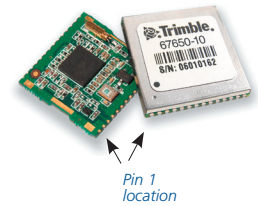

Condor C1919

The C1919C variant has built-in antenna detection for open and short circuit conditions; alerts are on by default, but can be turned off by command.

The C1919A variant is available mounted on a carrier board [P/N 63531-10] or in a complete starter kit for quick testing and integration [P/N 70291-10].

Choose the Condor C1919 for top tier positioning performance, the best components, and the highest production quality standards.

PIN OUT TABLE

PIN#	FUNCTION	I/O	DESCRIPTION
1-2	GND		Ground
3	RF_IN	Input	GPS signal input 50 Ω unbalanced (coaxial) RF input
4	GND		Ground
5	Reserved		Do not connect
6	V _{rtc}	Input	Optional backup power 2.0 V to V _{cc}
7-10	Reserved		Do not connect
11	XRESET	Input	Pull low 100 ms for reset; do not connect if not used
12	V _{cc}	Input	Main power supply 3.0 V to 3.6 V
13-15	GND		Ground
16-18	Reserved		Do not connect
19	PPS	Output	PPS Interface Time pulse
20	RXD	Input	Serial port Receive @ 2.8 V LVTTL
16-18	Reserved		Do not connect
24	TXD	Output	Serial port Transmit @ 2.8 V LVTTL
25-26	Reserved		Do not connect
27-28	GND		Ground

GPS PERFORMANCE SPECIFICATIONS

GPS performance statistics are clear view, stationary. Sensitivity based on signals measured at the antenna.

PARAMETER	VALUE(S)
Update Rate	1 Hz (default), up to 5 Hz
Number of Channels	22
Accuracy	
Position (autonomous)	<2.5 m 50%, <5 m 90%
Position (SBAS)	<2 m 50%, <4 m 90%
Altitude (autonomous)	<5 m 50%, <8 m 90%
Altitude (SBAS)	<3 m 50%, <5 m 90%
PPS	< ±25 ns @ 50%
Acquisition time	
Re-Acquisition	2 s 50%
Hot Start	2 s 50%
Warm Start	35 s 50%
Cold Start	38 s 50%
Sensitivity	
Tracking	-160 dBm
Acquisition	-146 dBm
Dynamics	
Acceleration	2 g
Max Operational Velocity	515 m/s

ELECTRICAL SPECIFICATIONS

PARAMETER	VALUE(S)
Serial Interface – UART	1 bidirectional NMEA
Level	2.8 V LVTTTL level
PPS Interface	1 Hz timing pulse, output
Level	2.8 V LVTTTL level
PPS Accuracy to UTC	< ±25 ns @ 50%
Pulse Width	4.2 μs default (configurable)
GPS Input RF Interface	GPS signal input 50 Ω unbalanced (coaxial) RF input
Main Power Supply	
V _{CC} DC Levels	3.0 V to 3.6 V; 3.3 V typical
Consumption (current)	37 mA
RTC and Backup Power Supply	
V _{rtc} DC Levels	2.0 V to V _{CC}
Consumption (current)	5 μA typ @ +25°C

GPS COMMUNICATION PARAMETERS

GPS output is available from a serial interface (UART). The output adheres to NMEA 0183 protocol with the following characteristics.

PARAMETER	VALUE(S)
Protocol	NMEA 0183
Baud Rate	
Default	9600
Other	4800, 19200, 38400, 57600, 115200
Message Output Rate	Up to 5 Hz
Number of message types restricted by baud rate	

NMEA 0183 MESSAGES

MESSAGE	DEFAULT	DESCRIPTION
GGA	Default	GPS fix data
GSA	Default	GPS DOP and active satellites
GSV	Default	GPS satellites in view
RMC	Default	Recommended minimum specific GPS/Transit data
CHN	Other	GPS channel status
GLL	Other	Geographic position – Latitude/ Longitude
VTG	Other	Track Made Good and Ground Speed
ZDA	Other	Time and date

ENVIRONMENTAL SPECIFICATIONS

PARAMETER	VALUE(S)
Temperature	
Operating	-40 °C to +85°C
Storage	-40 °C to +105°C
Humidity	5% to 95% non-condensing @ 60°C
Vibration	
5 Hz to 20 Hz	0.008 g ² /Hz
20 Hz to 100 Hz	0.05 g ² /Hz
100 Hz to 900 Hz	-3 dB/octave

PHYSICAL SPECIFICATIONS

PARAMETER	VALUE(S)
Dimensions	19.0 mm x 19.0 mm x 2.54 mm
Weight	1.724 g including metal shield

ABSOLUTE MAXIMUM RATINGS

CAUTION–Absolute maximum ratings indicate conditions beyond which permanent damage to the device may occur. Electrical specifications do not apply when operating the device outside its recommended operating conditions.

PARAMETER		MIN	MAX	UNIT
Main power supply voltage	(V_{CC})	-0.3	4.0	V
RTC power supply voltage	(V_{RTC})	-0.3	4.0	V
Antenna input power at RF input	(dBm)		+10 max	dBm
Storage temperature	(T_s)	-40	+105	°C

RECOMMENDED CONDITIONS OF OPERATION

PARAMETER		MIN	MAX	UNIT
Primary power supply voltage ¹	(V_{CC})	3.0	3.6	V
RTC power supply voltage	(V_{RTC})	2.0	V_{CC}	V
Input pin threshold voltage (RXD, Reserved Pins, XRESET)				
with Status = High	(V_{IH})	2.0	V_{CC}	V
with Status = Low	(V_{IL})	-0.3	0.8	V
Output pin threshold voltage (TXD)				
with Status = Low ($I_{OH} = 1.6$ to 14 mA)	(V_{OH})	2.4	V_{CC}	V
with Status = High ($I_{OH} = 1.6$ to 14 mA)	(V_{OL})	-0.3	0.4	V
Hardware XRESET (assert XRESET pin)	(XRESET)	100		ms
Ambient operating temperature	(T_A)	-40	+85	°C

1. See "Supply Voltage Requirement" below.

ELECTRICAL CHARACTERISTICS

Characteristics apply to corresponding operating conditions as stated, with typical @25 °C. Measurements are made over temperature range -40 °C to +85 °C. Measured results are typical and do not guarantee performance.

PARAMETER	MIN	TYP	MAX	UNIT
Current Draw, continuous tracking (excluding antenna supply)	31	37	42	mA
Power Consumption, continuous tracking (excluding antenna supply)	93.00	122.10	151.20	mW
Current Draw, standby mode (V_{rtc} pin only; $V_{RTC} = 2.96$)		5		µA
Current Draw, standby mode using serial command (V_{CC} and V_{rtc} pins)		2.42		mA
Supply Ripple Noise, 1 Hz to 1 MHz			50	mVpp
Supply Ripple Noise, GPS TCXO freq 16.368 MHz ± 5 kHz			1	mVpp
Input Gain at RF Input	0 (passive antenna)		25	dB
External LNA noise figure			2	dB

SUPPLY VOLTAGE REQUIREMENT

The Primary Supply Voltage (V_{CC}) slope from 0 V to 2 V must have a rise time that is less than 10 ms.

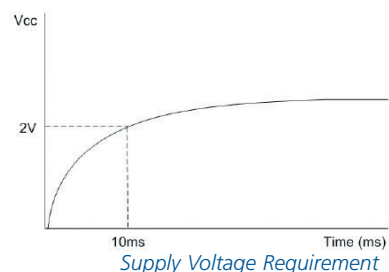

FEATURES

Antenna Input RF_IN (Pin 3)

The RF input pin is the 50 Ω unbalanced GPS RF input, and can be used with active or passive antennas.

Antenna Detection in C1919C Only (not in C1919A)

The C1919C has built-in antenna circuit status detection for open and short circuit conditions (for use with active antenna applications). By default, the open and short alerts are turned on. You can turn them off using the \$PMTK324 command.

The SHORT alert is triggered if more than 19 mA is drawn from the antenna pin; the current is further restricted to a maximum of 33 mA by a current clamp.

This diagram shows the active antenna drawing current through an internal 10 Ω sense resistor, supplied by an internal 2.8 V regulator. As a result, there will be an associated voltage drop as the current increases.

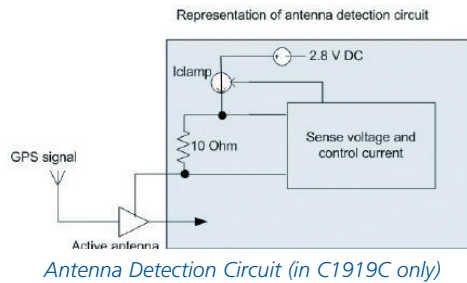

PPS – Pulse-Per-Second Output (Pin 19)

This logic level output provides a 1 Hz timing signal to external devices. The default pulse width of this signal is 4.2 μs. (The pulse width is configurable by using the \$PMTK324 command.)

For timing applications, you must capture the time from the ZDA timing message. Position messages contain a timestamp that can be 1 to 2 seconds in the past. Therefore, you can take the following steps to ensure that you acquire the correct time.

Do the following to acquire the correct time:

1. Confirm that the UTC offset has been downloaded (\$PMTK457) and that the receiver is generating 3D fixes (GSA). This eliminates the UTC offset jump.
2. Confirm that the receiver is configured so that it only outputs a PPS on a 3D fix (\$PMTK424).
3. Capture the time from the ZDA packet. Once time is acquired, add 1 to the whole second on the next PPS for the correct time.

Serial Port Default Settings (Pins 24, 20)

The Condor C1919 GPS module supports one serial port. Baud rate is user configurable. Data bits, parity and stop bits are not. Flow control is not available.

Serial Port Default Settings

PORT DIRECTION	PIN #	PROTOCOL	CHARACTERISTICS				
			Default Baud Rate	Data Bits	Parity	Stop Bits	Flow Control
TXD	24	NMEA out	9600	8	None	1	None
RXD	20	NMEA in	9600	8	None	1	None

XRESET (Pin 11)

Connects to the host system reset controller or GPIO for host-controlled resetting of the GPS module.

APPLICATION NOTES

Application Circuit for C1919C

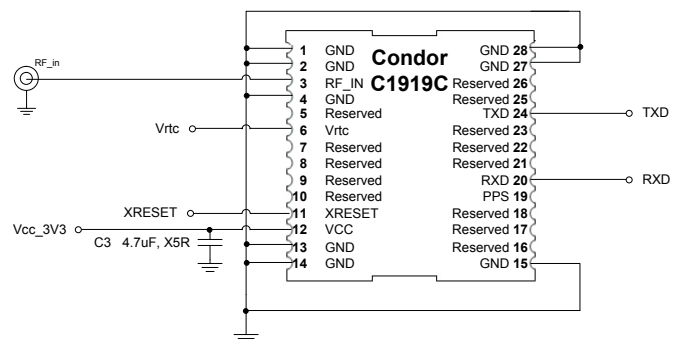

Notes for C1919C Application Antenna Circuit

- A backup battery may be connected to pin 6 (V_{rtc}) to maintain the current GPS data and RTC if main power is removed. If a backup battery is not used, leave pin 6 (V_{rtc}) either unconnected or connected to V_{CC}.
 - The external XRESET pin, connected to the host microcontroller or host reset controller, is pulled low for 100 ms after power is applied to V_{CC}.
 - Do not connect any of the Reserved pins.
- See "Supply Voltage Requirement" on page 3.

Application Circuits for C1919A

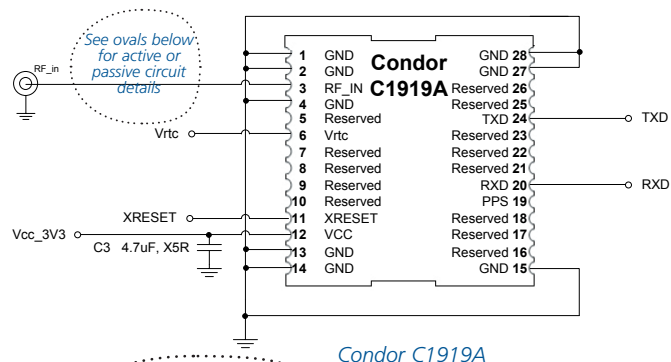

Condor C1919A

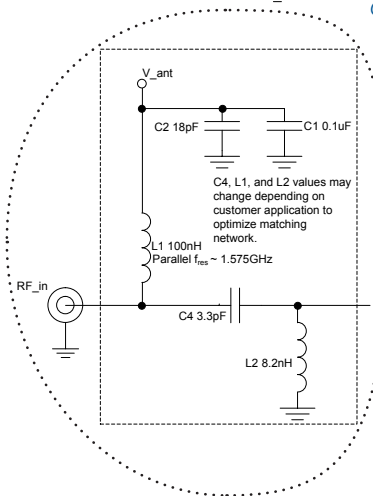

Condor C1919A with an Active Antenna

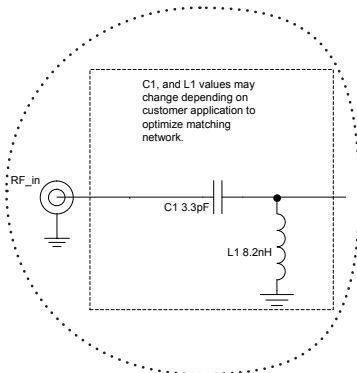

Condor C1919A with a Passive Antenna

Notes for Condor C1919A Antenna Circuits

- The external LNA gain range is 17 dB to 25 dB.
- You can optimize the values of:
 - _ L2 and C4 (for C1919A with an Active Antenna), or
 - _ L1 and C1 (for C1919A with a Passive Antenna)
 by applying a GPS signal from a simulator and adjusting the component values (up and down) to determine the best combination that provides the maximum displayed C/N value from the constant-level GPS signal. Alternatively, use a network analyser to optimize the input return loss.
- A backup battery may be connected to pin 6 (V_{rtc}) to maintain the current GPS data and RTC if main power is removed. If a backup battery is not used, leave pin 6 (V_{rtc}) either unconnected or connected to V_{CC} .
- The external XRESET pin, connected to the host microcontroller or host reset controller, is pulled low for 100 ms after power is applied to V_{CC} .
- Do not connect any of the Reserved pins.

See "Supply Voltage Requirement" on page 3.

SOLDERING INFORMATION

When soldering the Condor module to a PCB, keep an open cavity underneath the Condor module.

Do not place copper traces or solder mask underneath the module.

Solder Mask

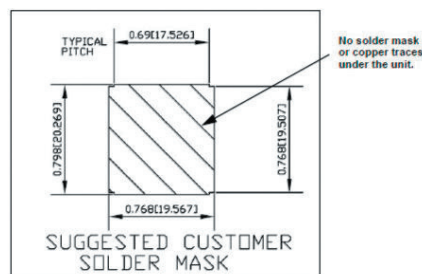

Pad Pattern

The suggested customer pad pattern is shown below.

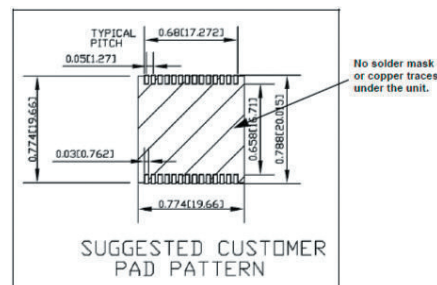

Paste Mask

To ensure good mechanical bonding with sufficient solder to form a castellation solder joint, use a solder mask ratio of 1:1 with the solder pad.

When using a 5 ± 1 mil stencil to deposit the solder paste, Trimble recommends a 4 mil toe extension on the stencil.

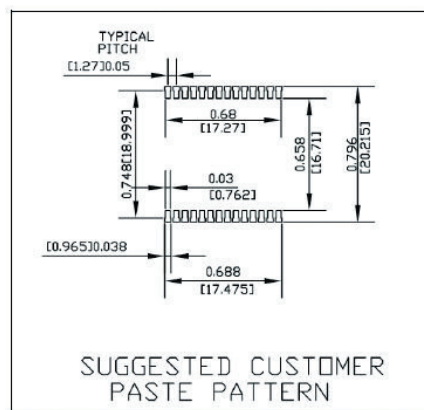

MECHANICAL OUTLINE DRAWING

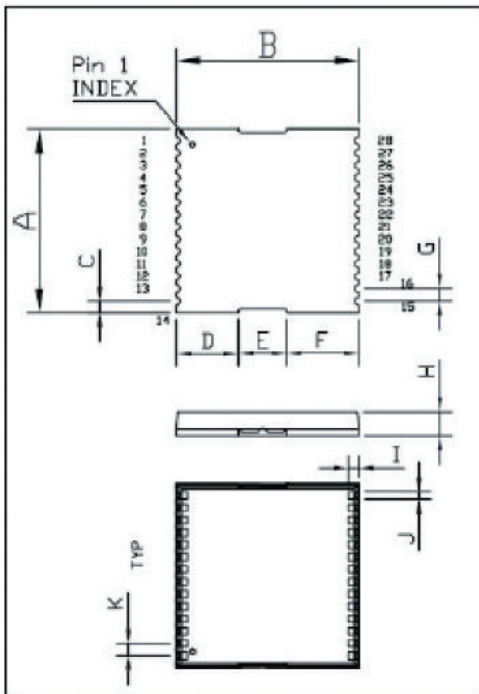

Top View

Bottom View

Outline Dimensions (Inch ± 0.004 / mm ± 0.10)

A	B	C	D	E	F	G	H	I	J	K
0.75	0.75	0.049	0.256	0.197	0.295	0.050	0.100	0.045	0.030	0.050
19.00	19.00	1.25	6.50	5.00	7.50	1.27	2.54	1.14	0.76	1.27

ORDERING INFORMATION

Model	Part #	Packaging			Carrier Board P/N	Starter Kit P/N
		20-pc tray	100-pc reel	500-pc reel reel		
C1919A	67650-10	✓	✓	✓	63531-10	70291-10
C1919C	67650-20	✓	✓	✓		

SUPPORT INFORMATION

Get support information, including documentation and support software, at trimble.com:

<http://www.trimble.com/embeddedsystems/condor-gps-module.aspx?dtID=support>

Note: See the *Condor Series GPS Modules User Guide* for RF Layout Considerations and Soldering Guidelines.

NORTH AMERICA

Trimble Navigation Limited
Corporate Headquarters
935 Stewart Drive
Sunnyvale, CA 94085
+1-800-787-4225 Phone
+1-408-481-7741 Phone

Email: AD_Sales@trimble.com

EUROPE

Trimble Navigation Europe
+46 70-544-10-20 Phone

KOREA

Trimble Export Ltd, Korea
+82-2-555-5361 Phone

CHINA

Trimble Navigation Ltd, China
+86-10-8857-7575 Phone

